

Silicon NPN Power Transistors

2SC5100

DESCRIPTION

- With TO-3PML package
- Complement to type 2SA1908

APPLICATIONS

- Audio and general purpose

PINNING

PIN	DESCRIPTION
1	Base
2	Collector
3	Emitter

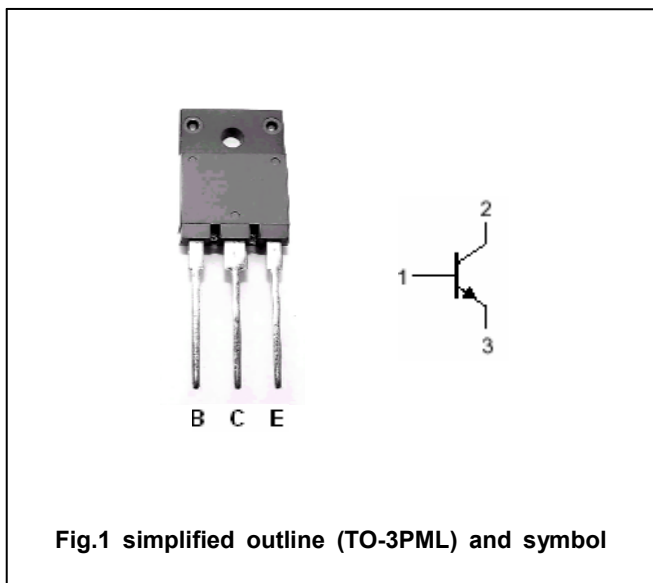

Absolute maximum ratings(Tc=25°C)

SYMBOL	PARAMETER	CONDITIONS	VALUE	UNIT
V_{CBO}	Collector-base voltage	Open emitter	160	V
V_{CEO}	Collector-emitter voltage	Open base	120	V
V_{EBO}	Emitter-base voltage	Open collector	6	V
I_C	Collector current		8	A
I_B	Base current		3	A
P_C	Collector power dissipation	$T_C=25^\circ C$	75	W
T_j	Junction temperature		150	°C
T_{stg}	Storage temperature		-55~150	°C

Silicon NPN Power Transistors

2SC5100

CHARACTERISTICS

T_j=25 °C unless otherwise specified

SYMBOL	PARAMETER	CONDITIONS	MIN	TYP.	MAX	UNIT
V _{(BR)CEO}	Collector-emitter breakdown voltage	I _C =50mA; I _B =0	120			V
V _{CEsat}	Collector-emitter saturation voltage	I _C =3 A; I _B =0.3 A			0.5	V
I _{CBO}	Collector cut-off current	V _{CB} =160V ; I _E =0			10	μA
I _{EBO}	Emitter cut-off current	V _{EB} =6V; I _C =0			10	μA
h _{FE}	DC current gain	I _C =3A ; V _{CE} =4V	50		180	
f _T	Transition frequency	I _E =-0.5A ; V _{CE} =12V		20		MHz
C _{OB}	Output capacitance	I _E =0; V _{CB} =10V; f=1MHz		200		pF

Switching times

t _{on}	Turn-on time	I _C =4A; R _L =10Ω I _{B1} =-I _{B2} =0.4A V _{CC} =40V		0.13		μs
t _s	Storage time			3.50		μs
t _f	Fall time			0.32		μs

◆ h_{FE} classifications

O	P	Y
50-100	70-140	90-180

Silicon NPN Power Transistors

2SC5100

PACKAGE OUTLINE

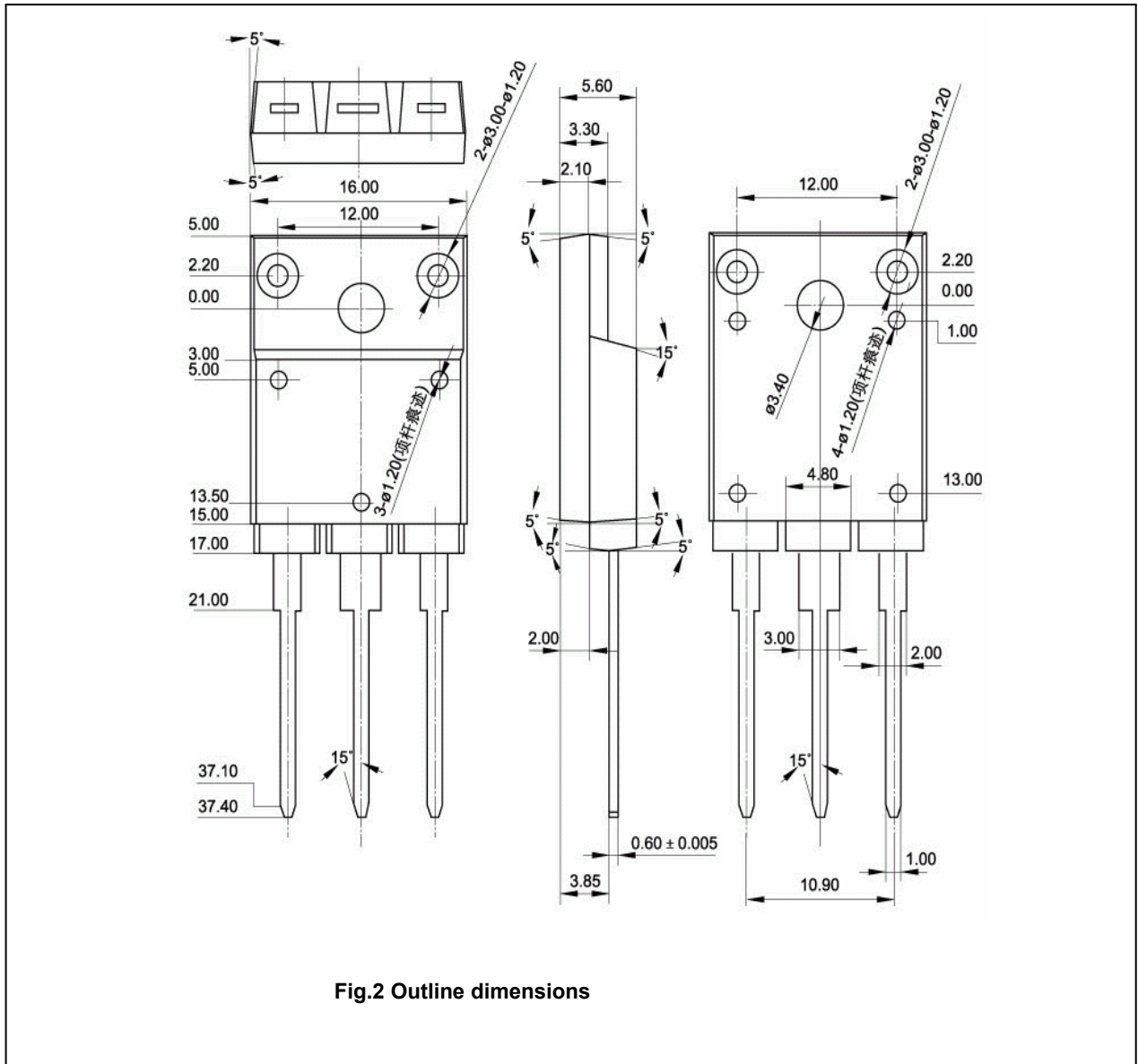

Fig.2 Outline dimensions

Silicon NPN Power Transistors

2SC5100

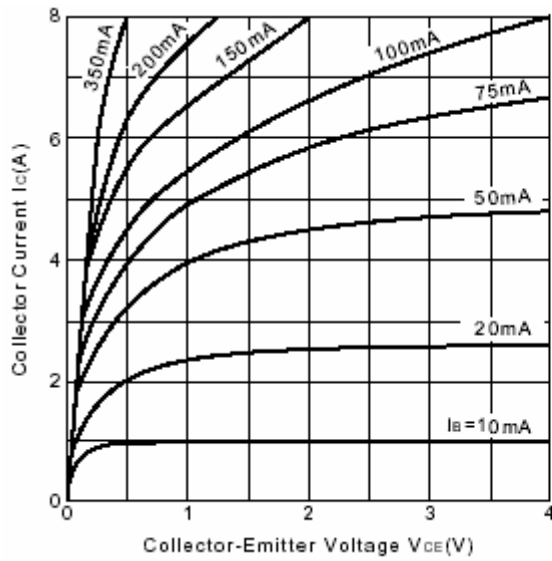

Fig.3 Static Characteristic

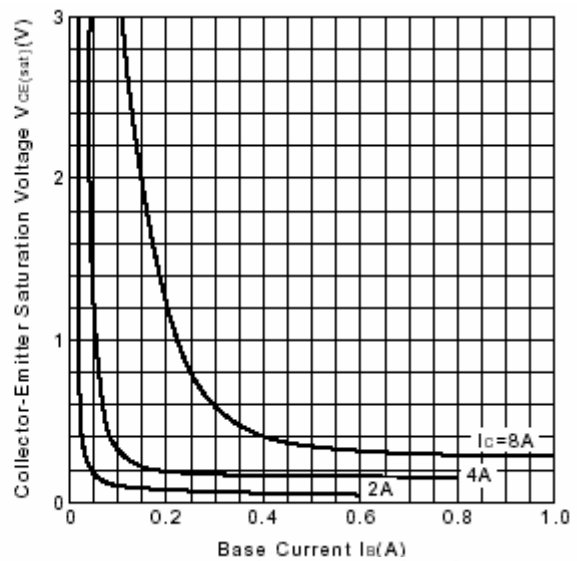

Fig.4 $V_{CE(sat)}$ - I_B Characteristics

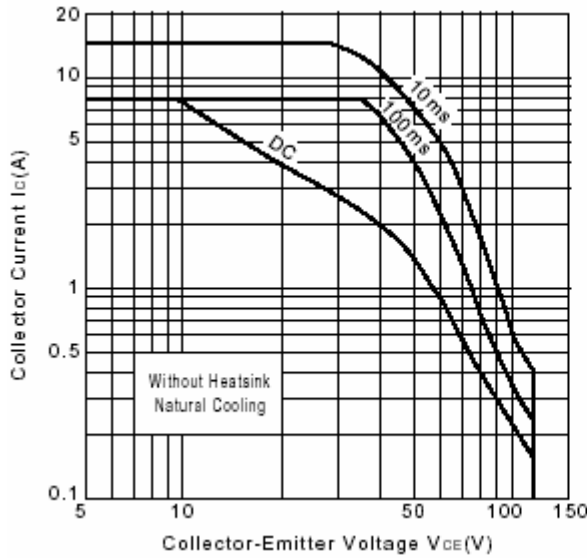

Fig.5 Safe Operating Area

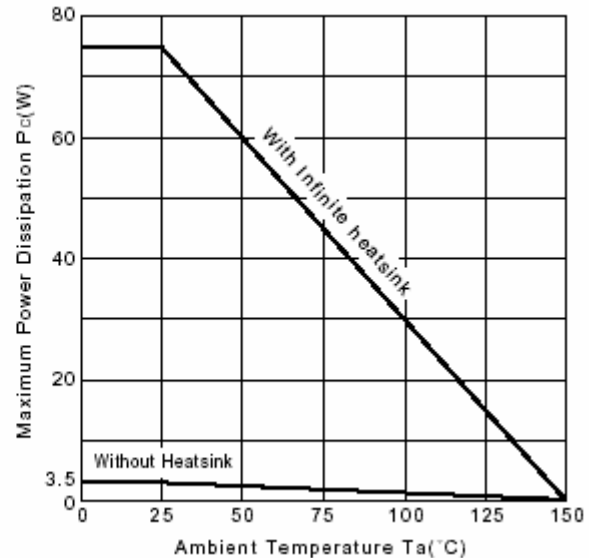

Fig.6 P_c - T_a Derating

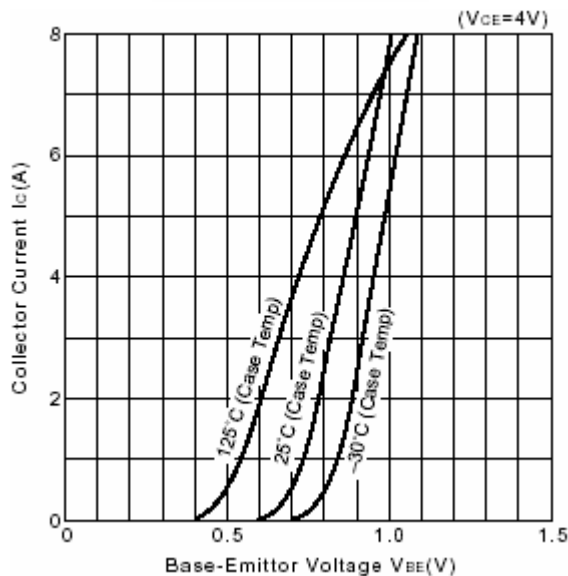

Fig.7 I_C - V_{BE}

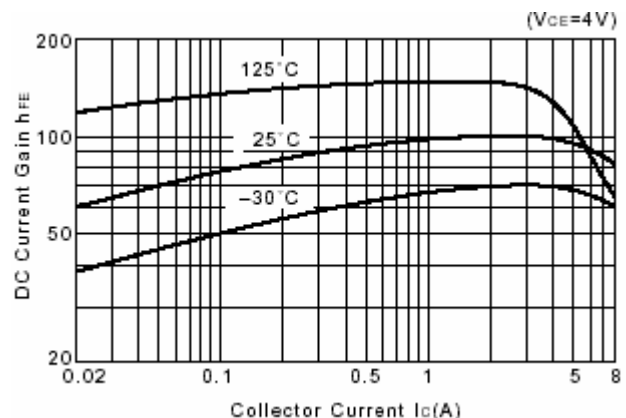

Fig.8 DC current Gain